

Residential Drainage

A HOMEOWNER'S GUIDE TO DRAINAGE PROBLEMS AND SOLUTIONS

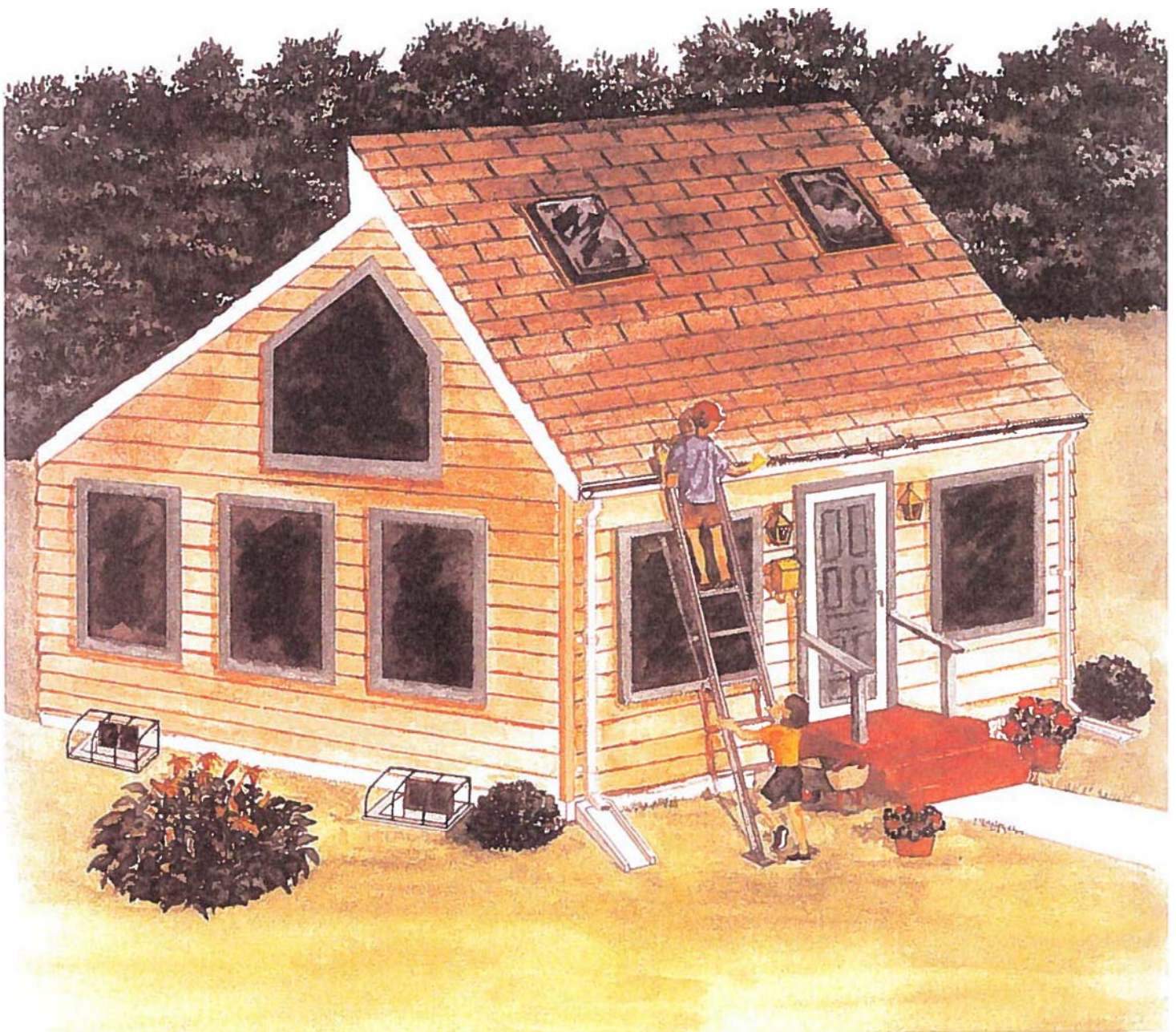

Residential Drainage

A HOMEOWNER'S GUIDE TO DRAINAGE PROBLEMS AND SOLUTIONS

Contents

1. Introduction	1
2. Basement Flooding Problems	1
2.1 Basement Construction	1
2.2 Primary Causes of Basement Flooding.....	2
2.2.1 Break in Waterline Connection or House Plumbing.....	2
2.2.2 Direct Inflow of Surface Water	2
2.2.3 Surface Water Infiltration.....	3
2.2.Li Groundwater Infiltration.....	5
2.2.5 Areaway Drain Surge or Blockage	5
2.3 Determining the Best Course of Action.....	6
3. Basement Waterproofing & Drainage Systems	6
3.1 Repairing Exterior Walls	6
3.2 Exterior Barriers & Soil Treatments	7
3.3 Interior Wall Treatments.....	7
4. Sump Pumps	7
5. Wet Yards	8
5.1 Exterior Underdrain System	9
5.2 Private Drainage Systems.....	10
5.3 A Note About Maintenance.....	10
5.Li Rain Gardens	10
5.5 Mosquitoes.....	11
6. Grading Around the House	11
7. Erosion Problems	11
7.1 1 Yard/Lot Erosion.....	11
7.2 Preventing Erosion in Yards & Shallow Drainages	12
7.2.1 .1 Sod.....	12
7.2.2 .2 Planting New Vegetative Protection	12

*Management
Production Team*
PRINCE GEORGE'S COUNTY
DEPARTMENT OF THE
ENVIRONMENT
Sustainability Division

7.3 Erosion Checks.....	12
7.4 Streambank Erosion.....	13
7 A 1 Rip Rap	13
7.A.2 Gabions.....	14
7 A 3 Small Retaining Walls.....	14
8. Moving to a New Home.....	15
9. Septic Systems.....	16

APPENDICES

Appendix A Glossary	18
Appendix B Most Commonly Asked Questions.....	19
Appendix C Residential Drainage Maintenance Checklist.....	24
Appendix D Vegetative Ground Cover.....	27
Appendix E Guide to Other Agencies.....	28
Quick Reference Numbers.....	30

Trouble-Shooting Guide

BASEMENTS

- Standing water in basement-Section 2.2.1
- Silty water leaking in through walls-Section 2.2.3
- Damp or moldy walls-Sections 2.2.3 & 3.3; Appendix C. Q&A's 3 & 12
- Water entering basement-Sections 2.2.2, 2.2.3, 2.2.4, 2.2.5; Appendix C. Q&A's 9 & 11

YARD & DRAINAGE SYSTEMS

- Sump pump not working properly-Section 4.0; Appendix C. Q&A 6
- Areaway drain clogged/backing up-Section 5.1; Appendix C. Q&A 8
- Water backing up through pipe-Section 5.0; Appendix C. Q&A 4
- Septic system problems-Section 9.0
- Neighbor's drainage is flooding your yard-Section 5.0; Appendix C. Q&A's 14, 15, 17, 18, 23, 24 & 33

OTHER AREAS

- Water spots on ceiling-Section 3.3
- Stream bank eroding away-Section 7A Appendix C. Q&A's 3 & 4
- Stream overflows onto property-Sections 7.0 & 7.1; Appendix C. Q&A's 21, 25, 26 & 28
- Storm drain culvert is clogged-Appendix C. Q&A 19
- Mosquitoes-Section 5.5: Appendix C. Q&A 30
- How do I select a contractor? –Quick Reference Numbers. p. 30
- How do I look for water problems when buying a home?-Section 8.0; Appendix C. Q&A's 12, 22, 27, 32

YARDS

- Sink hole in yard-Appendix C, Q&A's 13 & 31
- Bare spots in yard-Appendix C, Q&A 2
- Standing water or ponding in yard-Section SA; Appendix C. Q&A's 2, 7, 13, & 25
- Soggy yard-Section 5.0

1.0 Introduction

Prince George's County encompasses an area of 464 square miles and includes portions of three major watersheds: the Potomac, Patuxent and Anacostia. This publication provides a basic description of the causes of wet basements, erosion problems, and wet yards and outlines several measures that can be undertaken by the homeowner to correct or help prevent these problems. In addition, this manual can be used by potential home buyers as a guide for understanding what to look for, and what constitutes good grading around a home.

Although we have attempted to present acceptable remedial measures specifically for homeowners, we understand that many homeowners will not be able to do this work themselves and will need to hire a contractor. This book will familiarize you with a variety of basic corrective measures. The information and drawings are basic and can be modified to fit your particular situation.

A guide to other government offices that may be of assistance on drainage control matters is contained in Appendix E of this publication. Readers undertaking remedial measures described in the publication are encouraged to contact the appropriate governmental agencies in their areas to define permit requirements and to obtain any technical assistance or advice. Before undertaking any of these remedial measures, be sure to contact the Department of Permitting, Inspections & Enforcement (DPIE) to obtain the required permits. Additionally, the law requires contacting Miss Utility, at 1-800-257-7777, to have underground utility lines identified prior to any digging activities.

2.0 Basement Flooding Problems

It is estimated that 90% of all homes having cinder block basement walls will leak within the first 25 years. Many of these problems are related to natural groundwater tables that fluctuate with seasonal changes.

2.1 Basic Basement Construction

Homes having basements are generally constructed on concrete footings upon which concrete or cinder block basement walls are constructed. However, basement walls of poured concrete, brick or other materials are sometimes used. Basement construction involves digging a large hole in the ground in which the basement of the house is built (Figure 1). In the bottom of the hole, trenches are dug and concrete is poured for the footings. The basement walls are then constructed on the footings.

At some point after the construction of the basement walls, a gravel bed is prepared for the basement floor slab. The floor slab is poured over this gravel, with the slab's edges resting on the previously placed footings. The area represented

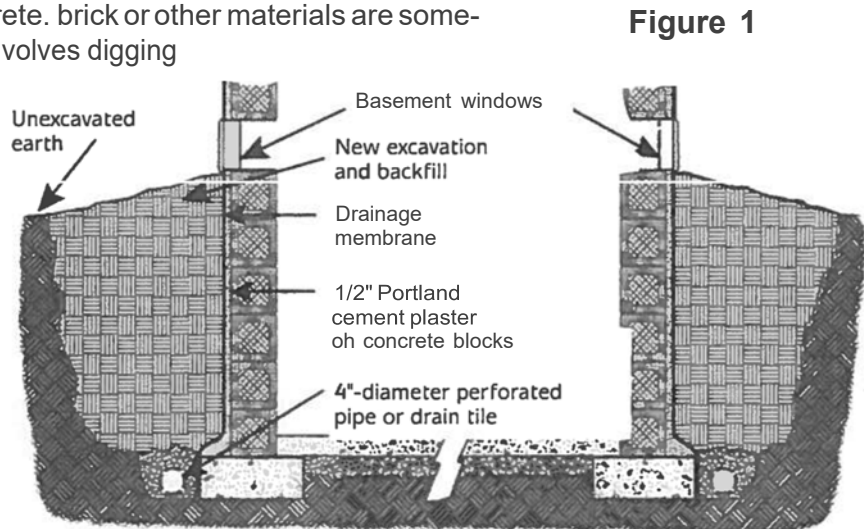

by the intersection of the floor slab, basement walls and the footings are referred to as the "cove area." Based on Prince George's County's Building Code, the builder is required to treat the exterior face of the walls. This treatment consists of applying cement (also known as parging) to the outside surface of the basement walls. Application of additional materials, such as asphalt coatings covered with polyethylene sheeting over the parging, generally completes the waterproofing process.

Frequently, perforated pipe underdrains (also known as foundation drains) are used to carry water away from the exterior basement walls. They are normally placed around the perimeter of the house, ideally below the intersection of the footing and wall. In areas where soils with poor drainage characteristics are predominant, these underdrains are considered essential.

At some point after or during the construction of the house, the space between the outside basement wall and the edge of the foundation pit is filled in with earth. In practice, this fill material is not compacted to a density equal to that of the pre-existing undisturbed soils around the house. Because of settlement and density difference, the fill material is capable of conveying and holding more water than the soil around it and frequently provides a storage area for excess water.

2.2 Primary Causes of Basement Flooding

- Break in the Waterline Connection and/or Plumbing Problems
- Direct inflow of Surface Water
- Surface Water Infiltration
- Groundwater Infiltration
- Areaway Drain Surcharge or Blockage

2.2.1 Break in the Waterline Connection or House Plumbing

When trying to determine the cause of basement flooding problems, it is important to rule out the possibility of a waterline break first.

The easiest way to determine this is to turn off the main water valve and observe the water meter reading outside the home. Sometimes the leak is small and will not be noticeable on the meter without observing over an extended period of time. Water bills should be compared with the same period last year to determine discrepancies.

If the flooding is continuous, sudden, near plumbing lines or occurs regardless of wet or dry weather patterns, a leak should be suspected. If this is the probable cause, contact the Washington Suburban Sanitation Commission (WSSC) at 301-206-4002 for assistance. The WSSC can test the water to find out if it is from a pipe or a natural condition.

On the inside of the home, check for possible leaks or obstructions in plumbing, and pipe connections to appliances such as water heaters, washing machines, and condensation overflow from air conditioning units. For small leaks, check plumbing pipes for wetness or dampness. In all cases where internal plumbing problems are suspected, contact a licensed plumber for assistance.

2.2.2 Direct Inflow of Surface Water

This type of flooding is generally the result of overland surface drainage entering the basement via window wells, doorways, and/or cracks in the above-ground basement walls. This is often the easiest type of flooding to detect and remedy since it usually occurs during or immediately following a rainfall event and is visible at the points where the water enters.

What to look for-The soil around the foundation should be well compacted so that the soil's ability to absorb water is reduced. Be sure that water flows away from the foundation and does not back up and get "trapped" against basement walls. The ground abutting the window wells should be sloped away from the house. Plastic window well covers, found in most hardware or home improvement stores, also help prevent water from entering the house (Figure 2).

Make sure downspouts have "shoes" at ground level and that water drops onto a three-foot splash block and is directed away from the house (Figure 3). The intent here is to prevent the water from infiltrating into the fill material adjacent to the basement walls. Concrete splash blocks and rigid or flexible downspout extensions are commercially available for this purpose. Gutters need to be free of debris to keep water from spilling over the sides and next to the foundation wall of the house.

Prevention-Basement flooding from the ground surface can be prevented by raising door and window sills or by regrading the yard to establish positive drainage away from the house. Check basement windows and doors often to ensure the watertight integrity of the basement. Recaulking may be necessary if gaps or cracks are noticeable. When surface water inflows cannot be diverted by regrading, structural modifications may be necessary. These modifications may include constructing window wells and/or bricking shut openings. For your safety, be sure ingress/egress codes are not violated. Contact the Fire Department's Code Enforcement Office for assistance in this regard. All masonry work should be relatively watertight, and special care should be taken to seal joints and connections to exterior walls.

2.2.3 Surface Water Infiltration

Flooding or seepage from this source is usually dependent upon the following three inter-related factors:

- 1) The ground surface slope and resultant drainage of rainwater around the house perimeter;
- 2) The rate at which water infiltrates the soil around the house; and
- 3) The condition of the exterior basement waterproofing, the foundation wall, and the underdrain system, if one was installed.

What to look for-Surface water seepage begins a short time after it starts to rain, and ends shortly after the rain stops. Water seepage will be silty and noticed only in certain spots. Typically, flooding occurs when surface water collects or ponds on the ground surface adjacent to the home and infiltrates into the home. Water takes the path of least resistance and flows into the loose backfill adjacent to the basement walls. If the undisturbed soils surrounding the house are relatively impermeable and a properly functioning underdrain system is not present, this water will collect in the backfill soil. Water pressure then builds up against the exterior of the basement walls. The condition of the exterior waterproofing now becomes critical. Even if it is in good condition, the water may build up sufficient pressure to crack the basement walls and allow the water in. If the exterior basement waterproofing has deteriorated at any point, the water will enter there. In either case, the water

Figure 2

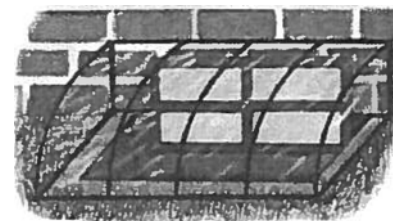

canopy attached to wall over window well

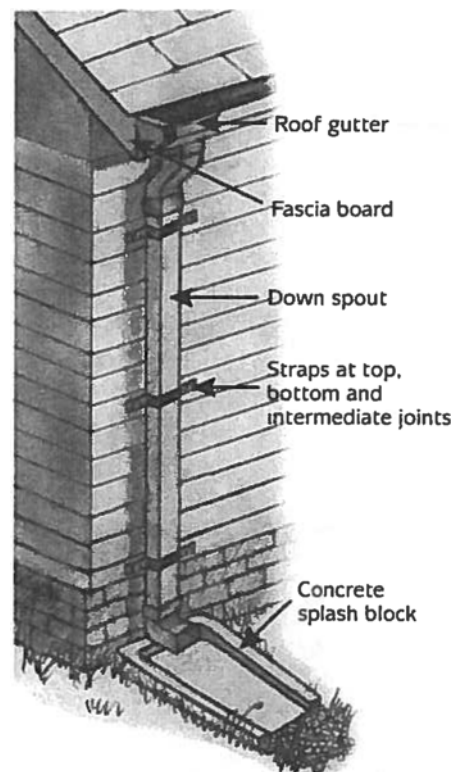

Figure 3

will be making a continuous effort to relieve the pressure it has built up on the outside of the basement walls by leaking into the basement. Since foundation walls are often constructed of concrete blocks which are hollow, a defect on the exterior surface of the wall may result in the lower courses of block becoming filled with water. If the interior side of the block is sound, this condition may go unnoticed for a considerable period of time until the interior surface begins to leak (Figure 4).

The most common water removal method is to place a perforated pipe under the slab around the inner perimeter of the basement. This pipe collects the water and is sloped in such a way that it will deliver the collected water to a suitable discharge point, such as a sump pump pit (Figure 5).

Indications that suggest this source of flooding include leaking cracks in the interior basement walls, and depressions or cracks in the soil which appear to be well drained in the ground surface adjacent to the house.

Prevention-Grading. to insure positive drainage away from all sides of the house, will aid in preventing the

entrance of surface water into the All material adjacent to the basement walls (Figure 6). Where All material is being used to raise the ground surface elevations, be sure to use a non-organic and root-free soil that is relatively impervious to water (such as clay). A word of caution concerning clay: clay materials can swell or "bulk," causing additional pressure

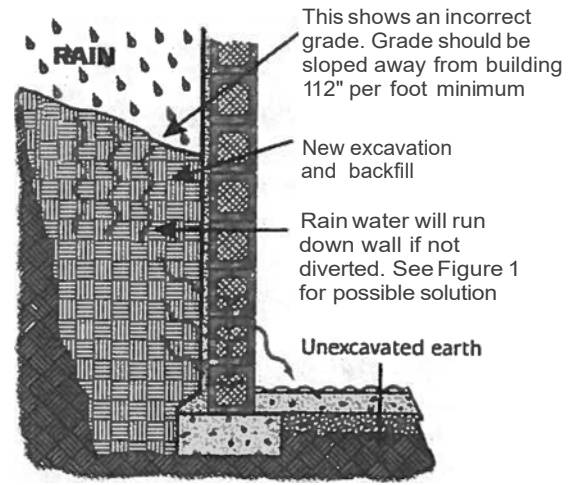

Figure 4

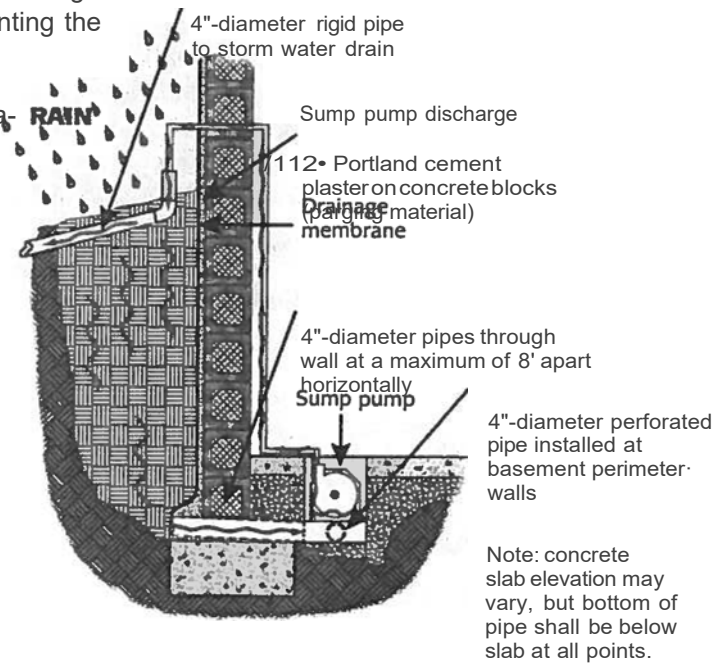

Figure 5

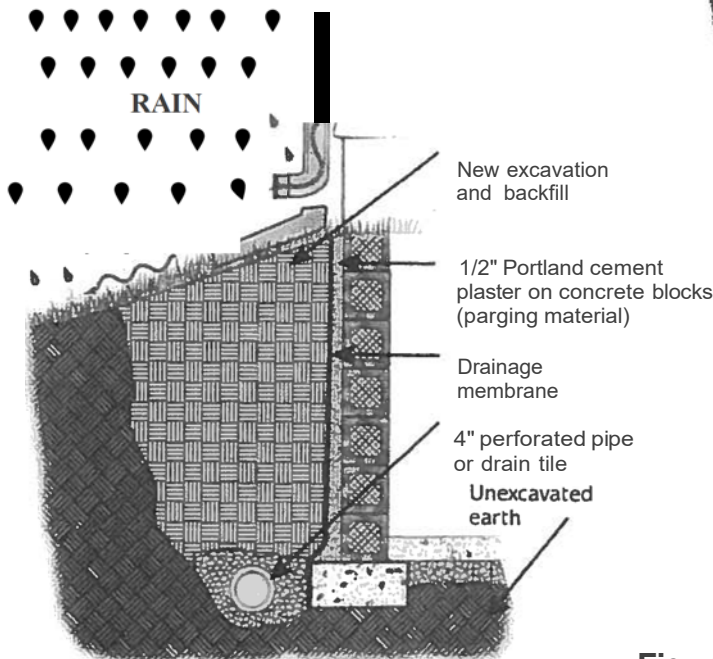

Figure 6-

against walls. Placement is critical. These soils, in turn, can be covered with topsoil and seeded or sodded after they are placed and compacted (Figure 7). Avoid planting large shrubs and trees next to the house. Penetration by the root systems of these plants provides an avenue for water to enter the fill material beside the foundation wall. Where concrete walkways, driveways, or patios have been placed next to the home, be sure to check for cracks along the joints next to the wall. Seal any cracks or joints with masonry-based caulking to prevent seepage.

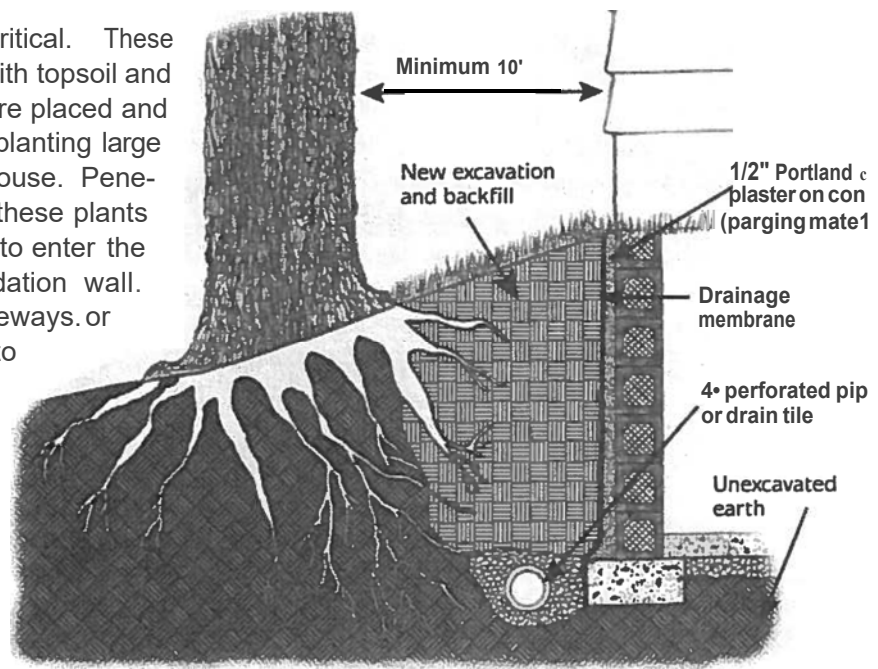

Figure 7

2.2.II Groundwater infiltration

Some homes have been constructed with the basement floor elevations below the elevation of the groundwater table. If this condition was recognized at the time of construction, an underdrain system with a gravity outlet or a sump pump may have been included as an integral part of the basement waterproofing. In some cases, seasonal or drought-induced lowering in the groundwater elevation may have hidden the fact that the situation existed. When the groundwater table is above the basement floor slab elevation, water pressure will be exerted against the exterior basement walls. If there is no functioning system to drain this water and relieve the pressure, the water will inevitably penetrate into the basement.

Indications that this is the source of flooding include seepage of water into the basement along the connection between the floor slab and the walls, and infiltration upward through cracks in the basement floor slab and around the outside of the basement floor drains during wet periods when the water table is high.

2.2.5 Areaway Drain Surcharge or Blockage

In some cases, basement flooding is the result of water being forced out of a drain under pressure. This situation can occur if the floor drains, foundation drains, etc. are connected to a sanitary sewer or public storm drain system which is at or near the basement floor elevation. If flooding from this source is suspected, the following should be done in this order:

- The water should be tested by the WSSC to make sure the condition is not related to a sanitary sewerage system source, and
- The elevation of nearby storm drain systems should be checked for blockages by the Department of Public Works and Transportation
- Areaways should be inspected often for leaves or other debris that would interfere with function.

If water being forced out under pressure is determined to be the cause of the flooding, an alternative means of discharge may have to be found for the floor drains or, in some cases, installation of a one-way discharge valve or back-flow preventer may be used to correct the problem.

2.3 Determining the Best Course of Action

Most of the flooding problems outlined in the preceding sections can be controlled by various waterproofing measures, or combinations of such measures. There are some instances where it may not be possible to completely eliminate the flooding problem due to specific site conditions, or the homeowner may not be able to undertake the necessary corrective measures. In these cases, it may be desirable to consider alternative uses for the basement area, such as storage of items not affected by water or dampness. If flood depths do not exceed several inches, appliances and heating equipment may be elevated on platforms or blocks and electrical connections may be relocated as necessary. **DO NOT USE** electrical appliances in the basement when it is flooded. Even a small amount of standing water can result in electric shock. In any case, a qualified service professional should be consulted.

The homeowner should make every effort to evaluate the severity of the flooding problem and determine the source of the flood water. This evaluation will provide a sound background for use in determining which remedial measure would be best suited to control the problem.

3.0 Basement Waterproofing and Drainage Systems

This section deals with water problems associated primarily with infiltration through walls and floors. Many of the required corrective measures may be beyond the capability of the typical homeowner; therefore, professional help may be needed. As the homeowner, you should contact several basement waterproofing firms to request cost estimates. Be sure to check references to verify that the contractor is reputable, and make sure the contractor is licensed. Keep in mind that costs can vary considerably between contractors. The remainder of this chapter provides an understanding of some of the methods used to correct basement flooding problems. See Appendix C for a homeowner maintenance checklist.

3.1 Reparging of the Exterior Basement Walls

A method frequently used to deal with basement seepage is reparging and/or repainting the exterior basement walls with a waterproofing agent. Parging—a 1/2"-thick mortar mix application used for waterproofing—is usually done when the house is constructed; however, settlement, freeze/thaw action and moist, highly acidic soil conditions can result in a deterioration of the parging materials. Reparging consists of exposing the basement walls down to the footing and removing the deteriorated parging where possible. The walls are then covered with a thin layer of waterproof cement and/or a waterproof tar compound, then covered by plastic sheeting. It is important to ensure a good seal of the coating material where the basement wall and the footing meet.

Information on the acidity and permeability of soils in your area can be obtained from the U.S. Department of Agriculture, Natural Resources Conservation Service or County Horticultural Agent, Agricultural Extension Service (see Appendix E for phone numbers). This information is useful when selecting an appropriate waterproofing system for your soil conditions.

It is important to remember that this type of reparging alone does not prevent a buildup of water pressure against the exterior basement walls. The

buildup of water pressure against the basement walls can be reduced if surface water and groundwater are prevented from entering the fill material next to these walls. Be sure the fill material is well compacted in shallow layers and has a low permeability. Grade the surface soils so that there is positive drainage away from the house on all sides. If your flooding problem stems from a groundwater source, it may be necessary to include an exterior underdrain system, described on page 9. When installed while the walls have been excavated for reparging, an underdrain system provides inexpensive additional insurance against seepage.

3.2 Exterior Barriers and Soil Treatments

These systems generally involve the injection of impermeable substances into the soil surrounding the house or the excavation of the fill materials around the house and the placement of impermeable material next to the basement walls. Typically the injection process requires special equipment and techniques. Materials used in the injection system are silicone compounds and bentonite clays. The intent of these systems is to create a wall of impermeable material designed to prevent the horizontal movement of soil water into the fill material outside the basement wall. One drawback of the injection method is that it does not lend itself to inspection during installation and, therefore, it is difficult to guarantee an unbroken wall of impermeable material. Success also depends on the experience and knowledge of the contractor and the type of soils being treated.

3.3 Interior Wall Treatments

Various types of waterproofing applications, typically in the form of paint, are commercially available. These materials, when properly applied to a sound wall, may help to control certain types of infiltration problems for a period of time. However, there is disagreement among the experts as to the overall effectiveness and desirability of using these products. While the coating may prevent water from entering the basement, the water pressure from the exterior can cause damage to the basement walls. As a precaution, when these products are used, every effort should be made to reduce the amount of water which can build up behind the basement walls.

4.0 Sump Pumps

These systems are designed to relieve hydrostatic pressure on the exterior basement walls and floors and do not require that the soil be excavated from around the exterior basement walls. Sump pumps are perhaps the most familiar of all methods used to de-water basements. They are simply electrically operated pumps, either submerged in or pumping out of a sump or pit. The sump is generally constructed so that its bottom is well below the basement floor slab. Water in the areas adjacent to the basement walls and floor migrates along the path of least resistance toward the sump pit. In some cases, it may be necessary to create a path of least resistance in the fill material for water to follow. In these cases, holes may be formed through the basement wall with pipe segments inserted to convey water contained in the fill. These pipe segments are then connected to larger diameter pipes running

along a gravel-filled trench or cove area into the basement floor leading to the sump pit (Figure 8). In some cases, these systems rely upon a degree of continued wall seepage or deliberate perforation. They are not recommended in cases where the quantity of inflow would be large, where the walls are cracked and weakened, or where a finished basement is desired.

Sump pumps are designed to prevent extensive basement flooding by pumping any excess water that reaches the inside of the basement. The most popular pumps are operated by electricity. Unfortunately, when a power outage occurs you are left with an inoperable sump pump.

There are supplemental sump pump systems and backup power sources that can be activated in the event of a power failure. One such system is a supplemental sump pump which is powered by the water pressure from the drinking water supply line. Other options include battery operated sump pumps and backup electrical generators. More information on these products can be obtained from local hardware and plumbing supply stores.

One of the most important things to consider when installing a sump pump system is to provide for an adequate outfall for the water which is expelled from the basement. The outfall should not be on a steep slope as this will contribute to potential erosion problems. The outfall should be placed at least 8-10 feet away from the foundation wall to prevent the effluent from merely infiltrating back into the ground and into the foundation drain system, only to reach the sump pump again. This "recycling" of water can be prevented by extending all downspouts and sump pump discharges an adequate distance from the house. Care should also be taken to prevent directing any discharges (sump pump, downspout, underdrains, etc.) onto neighboring properties or public areas such as sidewalks where a safety hazard can be created. This is especially important when lot sizes are relatively small or where steep slopes are involved. If caution is not taken, the drainage problem for one house is merely transferred to a neighbor. When discharging on private property, point of discharge should be at least ten feet away from the property line. Please note that sump pump discharges which flow from private property into the street right of-way and cross a sidewalk or curb are considered safety hazards. Improper discharging of water within the County rights-of-way is considered illegal. The homeowner can construct an underdrain system to be connected to the nearest storm drain inlet structure or to an existing road underdrain pipe system by special drain permit only. Special drain permits are obtained from the Department of Public Works and Transportation. It is important that homeowners do not connect any underdrains to their on-site sewage disposal systems or to any abandoned wells.

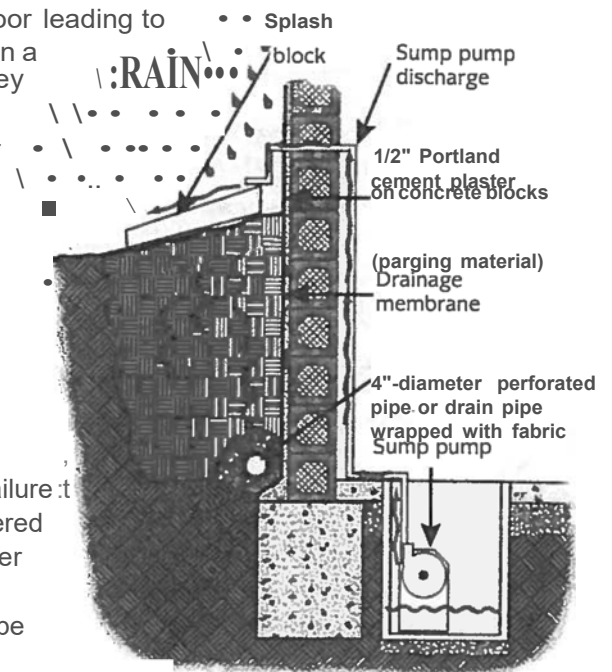

Figure 8

5.0 Wet Yards

The extent of surface water (rain) movement over and through the ground becomes very important once you have experienced house and yard flooding. Surface runoff is the result of water flowing from roofs, driveways, sidewalks, and surrounding properties. This excess water can lead to poor drainage and ponding. The standing water, in turn, may lead to the presence of mosquitoes and other annoying insects.

The best way to avoid ponding water in the yard is to make sure the yard is adequately graded. Any low spots or depressions in the yard will create an opportunity for water to pond. Swales should be graded to convey runoff through the yard and away from your house. Be sure that the land immediately adjacent to your house is sloped down and away from the foundation wall so as to prevent runoff from flowing directly toward the structure (Figure 9).

Excess runoff can be controlled by creating swales around the yard, and if necessary, surface drainage systems. Occasionally, soils are so saturated that they are beyond the point of accepting more water. Normally at this point, the homeowner would consider the installation of a private drainage system. In most cases, the surface drains can be aligned to permit their easy connection to the County's storm drain system.



Other methods to improve drainage in your yard are:

- Extend downspouts with corrugated plastic pipe. The pipe should be solid and not have holes in it.
- Remove obstructions that could retain water in the yard such as edging, rocks, bricks, etc.
- Install gravel trenches along driveways or patios to collect water and allow it to filter in the soil.
- Resod bare patches in lawn to prevent erosion.
- Install fencing so that the sectional bases are not in contact with the ground and water pathways are not obstructed.

5.1 Exterior Underdrain System

The advantage of an underdrain system is that it will remove water which would otherwise exert pressure against the basement walls and floor. In the past, underdrains usually consisted of clay tiles or clay pipe segments which were placed on a gravel bed with a gap of approximately one-half inch between pipe segments. The gap would allow water to enter the pipe segments and be carried to a discharge point. This type of system is prone to failure due to settlement of the clay pipe and the difficulty of cleanout operations. Modern underdrains (Figure 10) are generally constructed of continuous, perforated plastic pipe. This pipe is placed on a gravel filter bed with drain holes facing down and in some cases, covered with additional filter material to prevent soil from entering and clogging before backfilling. The underdrains are placed along the building foundation just below the footing and carry water they collect to a gravity discharge or sump pump pit for disposal in a public drainage system, a free-flowing natural drainage course or onto the ground surface.

If there are no adequate means of disposing of runoff through the site, homeowners should attempt to "work with" the water as it exists. Low lying areas can be creatively landscaped with water tolerant plants. These areas can enhance the look of your residential lot. Rain Gardens and other landscaped areas may be less expensive and more aesthetically pleasing when compared to drainage pipe systems. (See page 10 for more information concerning Rain Gardens.)

Figure 10

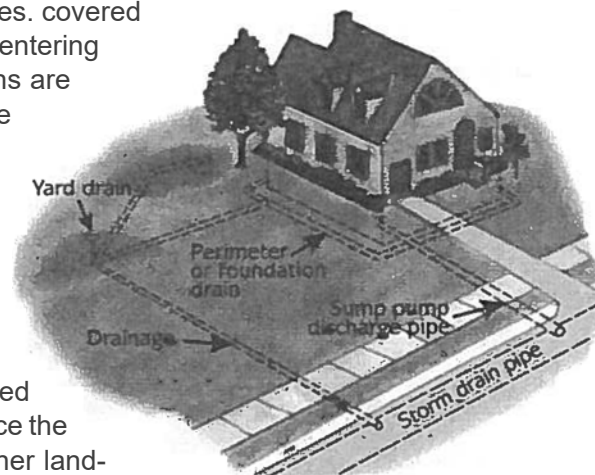

5.2 Private Drainage Systems

Drains are used to help de-water saturated soil or to drain low areas. They can alleviate wet basements by removing water from the soil before it enters the fill material adjacent to the basement wall. Drains are also used when it is desirable to keep the yard dry.

Simple drainage systems consist of trenches filled with gravel and perforated pipes (Figures 11&12). Depending on the conditions, drains may be augmented by the use of filter fabric. The effectiveness of this type of treatment is closely tied to three factors: (1) the existence of a suitable runoff point, (2) the depth of the trench and (3) the slope of the trench.

Streams, swales, ditches or slopes are suitable places to which the drain can be discharged. If such a discharge point is not available, an enclosed drain is generally not a good idea.

For drains placed around the perimeter of a house, the trench should be dug to a depth sufficient to ensure the capture of water that may infiltrate the fill material adjacent to the foundation wall. The slope of the trench should be such that good flow can be maintained between the gravel stones. This generally means a minimum slope of 1% or a drop ("fall") of 1/8 inch per foot of length. The same slope requirements hold for a drainage system anywhere on a particular property.

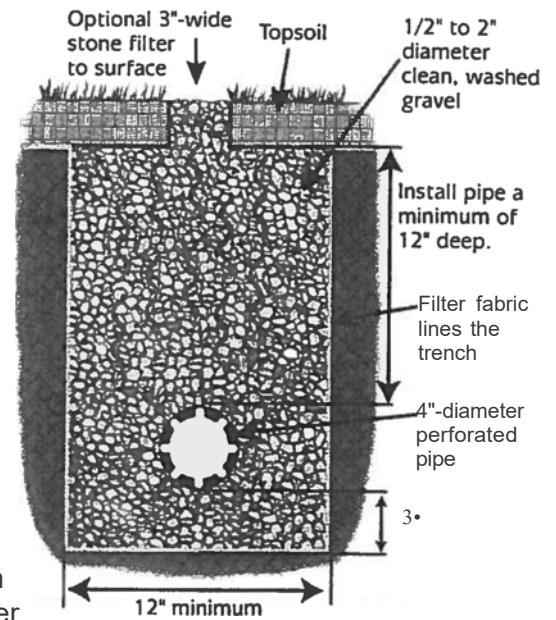

Figure 11
UNDERDRAIN DETAIL

5.3 A Note About Maintenance

When installing a drainage system, think about ease of maintenance. Make sure that the system has points of access at the ground surface (either inlets or cleanouts) located every 50-100 ft. for flushing or reaming.

5.4 Rain Gardens

The Prince George's County Department of the Environment has developed an innovative and environmentally sensitive approach to reducing stormwater pollution, which is also a feasible method for managing a wet yard. Rain Gardens are natural solutions that provide many benefits to the homeowner and the environment. These gardens are specially landscaped areas that use the concept of bioretention, a water quality practice in which plants and soils remove pollutants from stormwater (Figure 13). Rain Gardens are built into low-lying areas where

problems occur with standing water. Specific layers of soil, sand, and organic mulch filter the rain as it runs through the Rain Garden. The soil absorbs and stores the runoff which, in turn, nourishes the Garden's grasses, trees, and flowers. Instead of diverting this water into local streams and rivers, Rain Gardens filter and reuse this water, reducing stormwater pollution and soil erosion problems.

Rain Gardens can transform a muddy, wet yard into a beautifully landscaped garden that adds to the value of your home. They also require little maintenance, with no mowing required, and reduce the need for other costly stormwater management systems. This is one solution that works with nature and transforms problem areas into

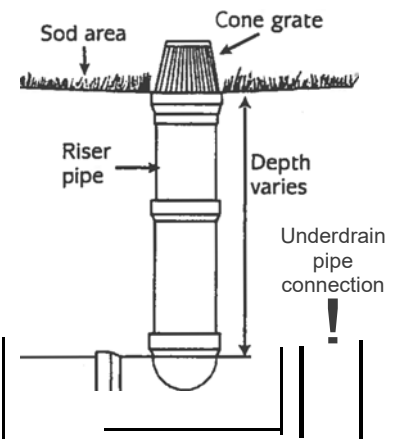

Figure 12
YARD DRAIN

CONNECTION DETAIL

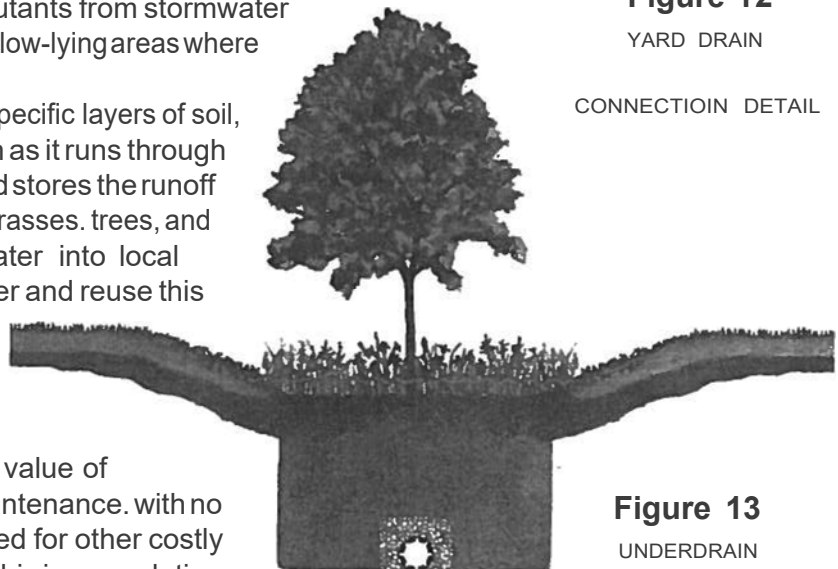

Figure 13
UNDERDRAIN SYSTEM

an attractive garden that basically waters itself. For more information on how to build a Rain Garden and what plants thrive in wet yards, call DoE's Sustainability Division.

5.5 Mosquitoes

Mosquitoes are most active after sunset, and near bodies of water. They can often be a nuisance if you have an extremely wet yard. There are several measures you can take to reduce the number of these insects in your yard:

1. Fill in any low spots with soil and seed to prevent "puddles." If necessary, perform minor regrading to provide positive drainage.
2. Install a Purple Martin bird house. Purple Martins eat thousands of mosquitoes a day. While it is true that they eat flying insects, don't expect these birds to wipe out your mosquitoes. Purple Martins also consume dragonflies which prey on mosquito larvae.
3. If you want to rid your yard of thousands of mosquitoes, put up a bat roosting box. One bat can eat thousands of mosquitoes a night.

According to the Prince George's County Health Department, "mosquitoes are not considered a health hazard in this area." To obtain information on attracting Purple Martins or bats, contact the Maryland Department of Natural Resources or your local library. For additional information on mosquitoes, contact the Maryland Department of Agriculture, Mosquito Control Office at (410) 847-5870 or (301) 475-9123.

6.0 Grading Around The House

Grading around a house can contribute greatly to flooding or erosion problems. If the ground does not slope away (downhill) from the foundation, water can pond around the base of the house and cause basement flooding problems. If the grading is flat or negatively sloped, surface water does not have a natural path to follow and will create ponding situations in the yard. Proper grading creates a positive slope away from the foundation of the house so water drains along swales or natural pathways to a free-flowing natural drainage course, such as a creek, or a storm drain inlet. When correcting grading problems, take care that your solution does not transfer the problem to your neighbor's yard.

7.0 Erosion Problems

This section deals with the causes of stream bank and yard/lot erosion problems. It describes recommendations for relatively inexpensive remedial measures that are designed to fall within the capability of many homeowners.

7.1 1 Yard/Lot Erosion

Yard/lot erosion problems are experienced by many homeowners, particularly where steep ground surface slopes, heavy foot traffic, or shaded, unvegetated areas are involved. In this type of erosion, it is not unusual for large amounts of topsoil to be gradually washed away with the subsequent loss of vegetation and the exposure of the ground surface.

This flowing water also leaches away the soil's nutrients, and inhibits the growth of stabilizing vegetation. If the velocity of this water is great enough, water often forms small streams. Scouring, which is the result of the action from these streams, will carve out small channels called "rills." that in turn, can develop into dangerous, unsightly gullies. In many cases, attempts have been made to cover these high erosion areas with fertile topsoils. Unfortunately, in most cases, this highly organic, loose soil quickly washes away, depositing additional silt downgrade.

7.2 Preventing Erosion in Yards and Shallow Drainages

The most important principle of preventing erosion is to have the ground as completely covered as possible with growing vegetation, or some substitute cover, such as mulch, burlap, flagstone, or gravel. The type of surface cover must be suited to the ground surface conditions. Mulch and small gravel are not appropriate for use on steep slopes or where high velocity flows are normal.

Figure 14

7.2.1 Sod

Sod provides an extremely effective and readily available source of protection for shallow intermittent drainages. When placed perpendicular to the direction of the water's flow (Figure 14) and firmly secured to the ground surface with wooden stakes or sod staples, the sod channel can "take hold" and provide an attractive, easy to maintain drainage course.

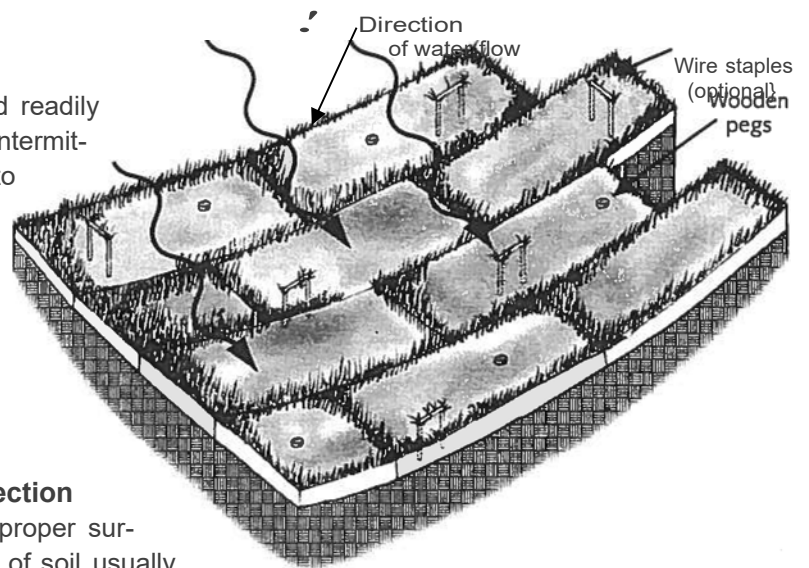

7.2.2 Planting New Vegetative Protection

When using any vegetative measures, proper surface preparation is essential. Since the loss of soil usually decreases its fertility, a soil test should be conducted prior to the planting of ground cover. This can be done by the State Agricultural Extension Service. Accompanying the results of the soil test will be planting recommendations, which can be used as a guide. Recommended grasses and other vegetative covers for the Washington Metropolitan Area are listed in Appendix D.

Prior to seeding the new turf, the surface of the soil should be raked or roughed to prepare a suitable seed bed. If the area will be subject to runoff before the plant cover is established, soil protection should be provided in the form of straw, burlap mats or commercially available soil mats. Mats of heavily woven jute or paper will hold soil in place on slopes, drainage ways, and other areas of intermittent concentrated flow. Some mats are designed to be placed over seeded surfaces; the grass will grow through the mat, which will eventually decompose as the turf becomes established. Proper watering of vegetative protection is imperative to establish root growth.

7.3 Erosion Checks

In areas where extensive erosion or gulling has occurred, it may be necessary to install simple timber or rock erosion checks. These measures will serve to trap eroding soils before they can wash downgrade and will help establish a

stable base for further landscaping efforts.

7.4 Stream Bank Erosion

Another common problem is stream bank erosion. This type of erosion is typically more difficult to control and the adequate corrective measures often involve structural solutions or techniques beyond the capability of the homeowner. Stream bank erosion is a natural process which can be expected to occur along all streams. Factors which affect the rate of stream bank erosion include: the soil types in the stream bank, the effectiveness of stream bank vegetation in retaining soils, stream flow velocities, and the frequency of small flood events.

It is important to understand that even though stream bank erosion is often a gradual process, major storms can result in rapid loss of large ground areas. In some cases, efforts to interfere with or control this erosion may appear to be futile as the power of the stream under severe conditions can undermine and remove even very massive structures. With this in mind, valuable improvements should be placed at least twice as far from a stream bank as the width between the banks whenever possible. These measures are especially important along the outside of a bend or just downstream from a bend in the stream.

A significant amount of erosion can also be prevented if the stream banks are protected by vegetation. Ask your local nursery for more information. Occasionally stream bank erosion is severe and significant restoration may be necessary. If you believe that an extreme stream bank erosion problem exists at or near your property, contact the Department of the Environment. Measures to control stream bank erosion should generally be considered when the erosion is creating a hazardous situation or severely limiting the use of the property.

The basic principle of any structural erosion control measure should be to provide a flexible or semi-flexible structure capable of withstanding minor damage. Rigid masonry structures are prone to irreparable damage due to loss of earth support, freeze/thaw action, and hydraulic forces. It is also important to ensure that any intended bank protection is secured to the stream bank (and channel bottom as necessary) in such a manner as to prevent water from flowing behind it and washing it out. If there is a possibility that the work under consideration will change the cross-sectional channel area, velocity or direction of the stream flow, local government regulatory agencies should be contacted for information on any permits required.

7.4.1 Rip-Rap

One of the most commonly used methods for stabilization of eroding stream banks involves the placement of stone revetments (facing material). Stone material used to protect stream banks is called rip-rap. Rip-rap protection can be achieved by dumping or placing stone over a prepared surface. Preparation of the eroding bank prior to placing stone should

include grading the bank to a slope gentle enough to ensure that the stone will stay in place. Porous filter fabric (non-woven), which is commercially available, is to be used between the stone and the underlying soil. The purpose of the filter fabric is to prevent fine soil particles

from washing out from under the stone. Filter fabric also helps distribute the weight of small rip-rap evenly over the slope surface (Figure 15).

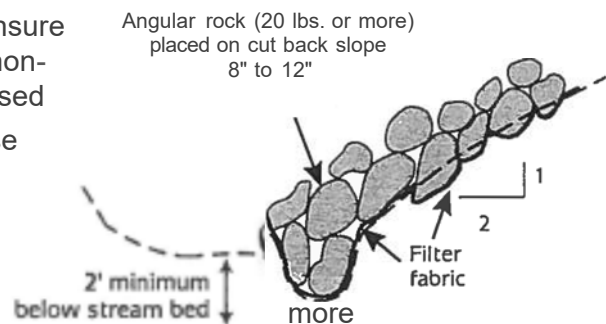

Figure 15

7.4.2 Gabions

Gabions are compartmentalized rectangular cages made of heavy galvanized steel wire mesh which, when they are filled with stone, become a flexible and permeable building block. The amount of stone required to fill the gabions varies with their size. Individual gabions are wired together and filled with stone of an appropriate size to form a continuous stone-filled mat or retaining wall. The completed structure forms a continuous layer and acts as a unit to stresses imposed by soil movement and hydraulic action. Frost heaving or normal ground settlement will only minimally affect these pervious structures. Water will seep through from behind the wall, preventing a buildup of hydrostatic pressure.

As with the installation of rip-rap, it is essential that the ground on which the gabions are to be placed is prepared to ensure a stable, permanent structure. When installed on the prepared surface, the gabions are held in place by anchors driven into the slope to prevent their migration downstream. This method is expensive and usually requires a contractor's assistance.

7.4.3 Small Retaining Walls

Small retaining structures placed at the base of eroding slopes will aid in stabilizing the slope material and help prevent the continuation of erosion. *The walls described in this section should generally be three feet or less in height.* Higher walls or those retaining a large amount of fill material involve special structural considerations, such as anchoring. These special considerations are not covered in this publication. With all stream bank retaining walls, care should be taken to ensure that the structure is not subject to undermining or washing out from the sides. In order to avoid these problems, the wall should be firmly anchored in the stream bottom and the upstream wall should extend into the stable stream bank.

Pre-packaged concrete represents one of the easiest methods of constructing retaining walls and stream bank revetments. Sixty- to ninety-pound bags of sand mix concrete

can be stacked and wetted while in place. By anchoring them to a prepared slope with reinforcing rods or staples, a permanent wall can be constructed (Figure 16).

Timber retaining walls represent an economical and easy method for slope and bank protection. The timber used should be rot-resistant. This generally means using redwood, cedar or pressure-treated pine. Holes for upright members of the walls should be dug with a fence posthole digger to a depth of approximately three feet. Posts are then secured by tamping earth around them or by setting them in poured concrete. If concrete is used, the posts should be set on a four-inch minimum layer of gravel to insure drainage below the post to help extend its life. Cross pieces can then be nailed to the post (Figure 17).

Cinder or masonry block retaining walls can be constructed using steel pipes or reinforcing rods as anchors. After a rod or pipe

Figure 16

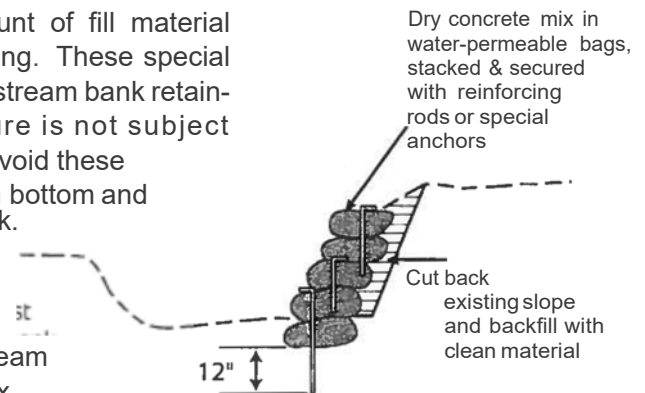
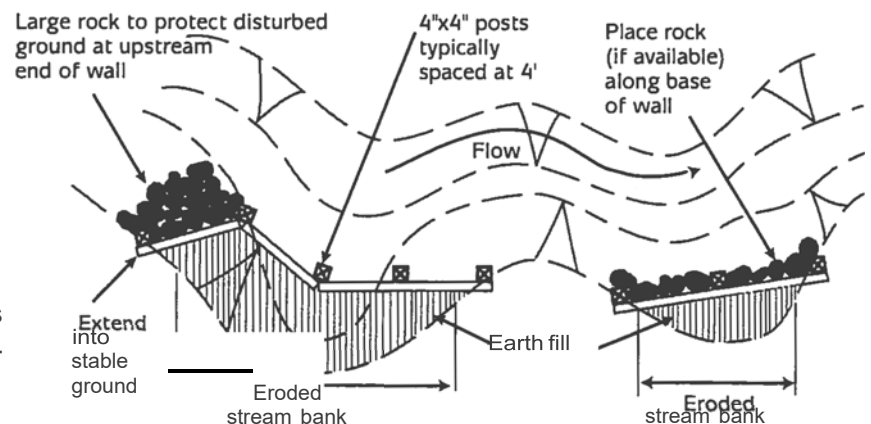

Figure 17



is driven into the ground, the block is laid down so that the pipe is running through the holes in the block. As each block is placed, the hole around the pipe or rod should be filled with earth and the earth tamped. This will form a tight but flexible area in which the pipe can take up the stress imposed on the wall from the fill behind it and renders mortaring unnecessary (Figure 18).

It must be emphasized that any stream will flood its banks from time to time and this will cause some degree of damage. The normally occurring alteration of erosion and sedimentation will result in natural stream meandering.

If the stream channel and its adjacent floodplain are left in a natural state, erosive damage will be minimized. When a floodplain area is disturbed (scrub growth and trees removed in favor of lawn, or grounds overused by children and pets), erosion problems would be expected to increase dramatically.

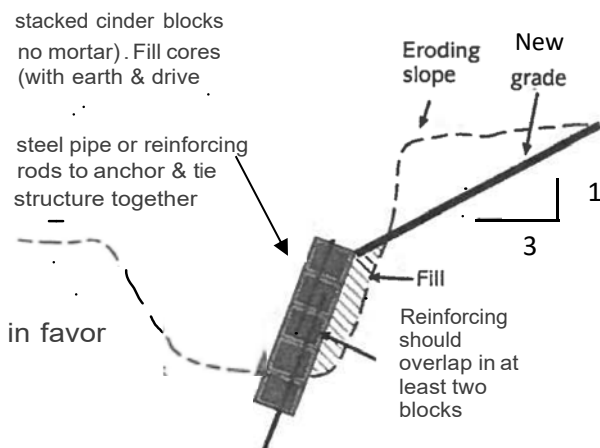

8.0 Moving To A New Home

Often, we are not aware of the potential drainage problems associated with a property. As we search for a new home, usually our main concerns are the schools our children will be attending, the uniqueness or stability of the neighborhood and, of course, the location of the potential new home. We never think about low-lying areas, high water tables, floodplains, or flood zones. We rarely think about water concerns inside the home much less the possibility of flooding. In this section of the manual, we hope to offer some tips and warning signs that may alert you to the possibility of current or future water problems.

As you are inspecting the outside of your potential new home, you should be aware of the vegetation growing near or on the property. Plants such as cattails, skunk cabbage and trees such as willow, red maple and elm could be an indication of wet soil. An area that is soft and spongy, especially when it has not rained, could be an indication of poor drainage. You will save yourself unnecessary worry and expense by looking for these potential problems before you buy. Remember, water problems are costly.

According to *Baybook/Citizens Program for the Chesapeake Bay*, here are some things to look for before you buy:

- Cracked basement or foundation
- Water stains on basement walls
- Standing water in basement
- Bright green spots in lawn (septic system malfunction)
- Sewage odor in basement
- Home site on same elevation as adjoining stream or river
- Wetland vegetation or conditions
- Soft, spongy ground
- Steep slopes
- Drainage ways
- Depressions in the soil surface
- For homes with well and septic systems, look for sewage ponding on top of the ground and areas of the property that have not been mowed.

In addition to the above, before selecting a residence, you should also

carefully consider the potential problems associated with homes located close to a stream or major drainage course, or those located at the base of a hill or with a significant "upslope" drainage area leading to your lot.

When looking at prospective properties to rent or buy, you should ask the management company or realtor if this property has any known drainage problems or if it is located in a floodplain area. If purchasing a home, a disclosure statement about floodplains and any flood insurance requirements should be included in the contract. When renting, an acknowledgement should be included in the lease for any tenant who will occupy any building situated within the Flood Hazard Boundary, or who would normally utilize a parking or storage facility area, any portion of which is situated within the Flood Hazard Boundary. Parking areas should be clearly posted to alert those using them that the areas are subject to flooding. Language pertaining to the Flood Hazard Boundary should read similar to the following:

"(1) In the event of heavy rainfall, the unit you are to occupy and/or the motor vehicle parking area and/or the separate storage facility (as the case may be) are situated within a Flood Hazard Boundary area and may be subject to flooding which could damage personal belongings and motor vehicles. Because of potential loss, you may be eligible for U. S. Government subsidized flood insurance on the personal belongings in your apartment building. Because of the danger of loss of your personal belongings due to flooding, you should consider acquiring flood insurance which may be purchased from most insurance agents.

(A) Damage to motor vehicles is not covered by such insurance; therefore, you should also determine whether you have proper motor vehicle insurance to cover loss due to damage of your motor vehicle resulting from flooding in the area.

(B) The tenant acknowledges reading and understanding the foregoing warning concerning flooding and the availability of flood insurance, and hereby assumes the risk of loss which may result from such flooding."

The above information can be found in the Prince George's County Code, Section 13-162.01. Rental facilities in flood areas; notice to prospective tenants.

9.0 Septic Systems

Usually, but not always, homes with septic systems are located in rural and suburban areas of the County where public water and sewer are not available. Septic systems have two key components for operation: a septic tank and a drainfield. The septic tank temporarily holds wastewater from the home (Figure 19). The drainfield is critical to how well your septic system functions. It distributes the effluent from the septic tank into the ground where it is filtered before it enters the groundwater. The drainfield must be large enough to absorb the daily wastewater from the home.

Individuals served by septic systems must contact the Health Department before implementing any of the drainage remedies suggested in this manual. Remember, the overall area designated for the septic system must not be disturbed.

Figure 19

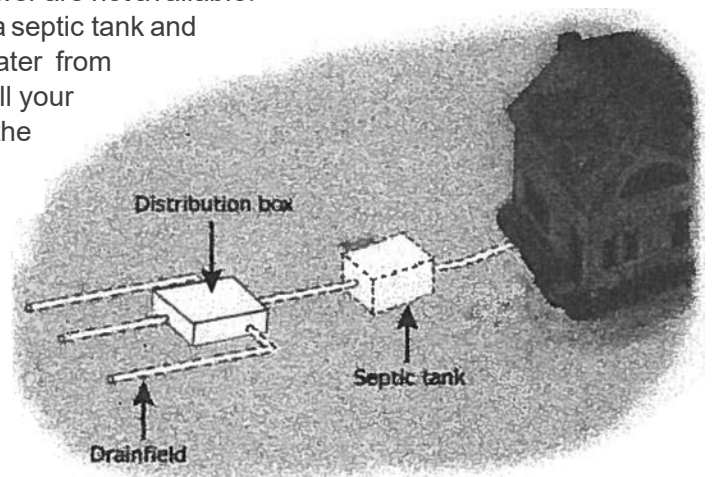

If you have doubts as to the location of your sewage disposal area, please contact the Health Department (301-883-7681). Certain remedies could possibly impede the function of their septic system. For instance, since most disposal systems are located on a lower elevation than the house, it is important that any man-made drainage introduced by the homeowner, after initial home construction has been completed, be directed away from the sewage disposal area.

The following examples indicate that a problem exists in the septic system. If you notice one of these conditions on yours or a neighboring property, please contact the Health Department immediately for assistance.

- Dark gray or black liquid surfacing in the vicinity of the drainfields, distribution box or septic tank. The liquid material is usually very odorous. It is important that people and pets are restrained from entering areas where a suspicious malfunction exists.
- Toilets or other water fixtures within the lowest portions of your house drain slowly or begin to back up within the house.
- Soils on top of the sewage disposal system are constantly saturated and wet.
- The level of sewage within the septic tank is above the outlet tee (see owner's operation manual).

It is important that the Health Department be contacted if any of these conditions appear. However, please remember that before a licensed septic contractor can repair your system, a Sewage Disposal Permit or Work Order must be obtained from the County Health Department.

The *Baybook* tells us that the following is the proper way to maintain your septic system and keep it running smoothly:

- Know the location of all components of your septic system; keep heavy vehicles away from the system.
- Do not plant trees or shrubs near drain tiles since their roots can clog drain lines.
- Do not pour household chemicals down toilet or drain.
- Prevent overloading system by distributing laundry throughout the week
- Do not use garbage disposals. **(On-site sewage disposal systems are designed in this County to accommodate garbage disposals. While not prohibited, their use is discouraged.)**
- Do not use toilets as trash cans.
- Monitor your septic tank yearly and have a reputable contractor remove sludge and scum every three to five years.

APPENDIX A

Glossary

- DRAINAGE** Stormwater, snow melt, and surface runoff, or groundwater flows.
- DRAINAGE SYSTEMS** A natural or man-made system used for the purpose of collecting and disposing of drainage.
- EASEMENT** A non-possessing interest held by one person in land of another person whereby the first person is accorded partial use of such land for a specific purpose. Easements fall into three broad classifications: surface easements, subsurface easements, and overhead easements.
- EFFLUENT** A discharge or outflow of water that could contain pollutants such as untreated sewage or industrial wastes.
- EGRESS** The right of going out or exiting an easement or property.
- EROSION** The process by which the ground surface is worn away by the action of water.
- FASCIA BOARD** A 2" x 6" to 2" x 10" board fastened beneath the dripline of a roof's shingles (see Figure 3).
- GRADING** The purposeful movement and shaping of soils by man.
- INGRESS** The right or permission to enter an easement or property.
- PARGING** A mortar mix application, 1/2" thick used for waterproofing (see Figures 5, 6, 7 & 8).
- PERMEABILITY** The rate at which water passes through a material.
- SEEPAGE** Underground water emerging to a surface through soil and rock or basement walls.
- SILT** A sedimentary material consisting of fine mineral particles, between sand and clay particles in size.
- SUBSURFACE WATER** All water beneath the ground or pavement surface. Commonly referred to as groundwater.
- STORM DRAIN EASEMENT** These easements (either surface or subsurface) are acquired in order to install, operate, inspect and maintain storm drain facilities that serve the public.
- SURFACE DRAINAGE EASEMENT** An easement for above-ground storm-water conveyance. Specifically, this area may not have any structures, buildings or improvements, nor can they be filled or excavated. The intent of this surface drainage easement is to keep the designated area open and free of obstruction to allow stormwater to pass through the area. The County does not maintain or own this area, but can require obstructions to be removed if the flow of stormwater is obstructed.
- WATERSHEDS** The land area that contributes runoff to a particular stream or drainage course.
- WATER TABLE** The upper limit of water in a saturated soil or underlying material

APPENDIX B

Most Commonly Asked Questions

1. My sump pump runs almost continuously. What can the County do to correct it?

Sump pumps run continuously if the groundwater table is high or if the water level that triggers the pump float to run is set too low. Additionally, if the sump pump discharge pipe does not carry the water far enough from the foundation, the water will filter back into the sump pit and the sump pump will run continuously to recycle this water. The Department of the Environment (DoE) can investigate the situation and make suggestions to the homeowner on ways to direct water drainage away from the home. See page 7 for more information.

2. My backyard is constantly wet and I am unable to grow any grass. What can the County do to correct this?

The County can send someone out to evaluate the situation and provide technical advice. However, if you are at the lowest point in the neighborhood, there may not be any way to prevent the yard from staying wet. See page 10 and Appendix D for more information.

3. My basement has a damp, musty smell. What can I do to correct this problem?

Contact a waterproofing/damp proofing company to determine if and where water may be entering the basement and to inquire about corrective measures. You could also purchase a dehumidifier.

4. Water is entering my basement/sump pit even during periods of no rain. How can I control it?

If possible, determine where water is entering. Water can be re-directed by installing an underground drainage system. Seasonal fluctuations of groundwater can cause seep conditions. You may also consider resetting your pump float level. See page 6.

5. I have a water seepage problem on the hill behind my home which is creating a major mess. How can I correct the problem?

It is generally the responsibility of the homeowner to correct this problem. Seasonal fluctuations of groundwater can cause seep conditions. Possible solutions: a) install a drain field and extend to adequate outfall or b) use the water to irrigate landscape areas. Plan landscape features to hide or absorb the water. For more information regarding landscaping, please request a copy of the County's Rain Gardens brochure.

6. My sump pump works okay while the electricity is on, but I am afraid of what will happen if the pump were to fail or the electricity goes out while I am away. What can I do to safeguard my property during these events?

There are "back-up" systems manufactured for sump pumps, or a battery or generator back-up power source can be used. A supplemental sump pump that runs off pressure from a public water line is another option. These items are available at your local hardware store.

- 7. There is a reddish, oily water seepage in my yard causing staining. I am concerned about a possible health hazard to my children. How can I have the water tested'?**

While this situation is unsightly, it probably does not present a health hazard other than slips or falls. If you have concerns about this substance posing a health hazard, contact the Health Department.

- 8. The area drain to my basement steps plugs up every time it rains. What are some methods I can use to keep the drain from blocking?**

Install a screen/drain guard cover to keep debris from clogging. Clean away any debris that collects over the screen/drain guard. It is the homeowner's responsibility to maintain this drainage system. Screens/drain guards can be purchased at your local hardware store.

- 9. I recently had my home waterproofed but water is still seeping in. What can I do?**

Install a sump pump and foundation drain, if you don't already have one. Contact your waterproofing contractor for additional help. Check your waterproofing warranty.

- 10. A leak has sprung up near the sidewalk in front of my home, causing icing and slime to form on the sidewalk. The problem is present all the time and does not appear to be affected by rain storm events. How can I determine if the seep is coming from a broken pipe or a natural spring?**

You can call the WSSC to determine if there is a water line in the vicinity, or call the County Department of Public Works to determine if there is a storm drain pipe in the area. Most likely, if the water is seeping all of the time and looks slimy, the cause is groundwater: If the problem is located within the roadway or County right-of-way, you may contact the Department of Public Works Highway Maintenance (301-499-8520) for assistance.

- 11. Water enters my basement every time it rains. What actions can I take to correct the problem?**

One of the first things to check is if the areaway drain outside your basement door is clogged. See page 6 for basement waterproofing measures. If drainage and waterproofing measures are in place and you are still having a significant problem, DoE can investigate to see if a drainage study is necessary to determine if a corrective project should be initiated.

- 12. I noticed an unpleasant odor in the basement of a home that I am considering purchasing. Should I be concerned?**

Yes. Consult your real estate agent or hire a home inspector. In Prince George's County, home sellers are required to provide information on known defects, including basement leakage problems. Ask direct questions and review the required disclosure or disclaimer forms.

- 13. Why did the County inspector let the builder build my house on a spring?**

County codes require a builder to cap a spring (provide drainage away from the foundation by piping to a suitable discharge location). but do

not necessarily prevent the construction of a home where one was located. Where water is encountered during construction, a foundation drain and sump pump pit are required. Additionally, the builder is required to "de-water" the foundation area during construction. Also, springs may shift over time and may not have been present during construction.

14. My neighbor is directing water toward my house. I want the County to issue them a violation.

Attempt to resolve the problem by discussing it with your neighbor. If you are unable to resolve the problem, or your neighbor will not cooperate, contact the License & Inspection Division, Prince George's County DPIE.

15. My neighbor has diverted water from its natural flow path. Can the County issue a violation'?

Depending upon the nature and extent of the work performed, the County may issue a violation notice. In most cases, County personnel will need to evaluate the situation to determine if enforcement action is warranted.

16. I would like to connect a private drainage system to the County's drainage system. Do I need a permit and can I accomplish the work myself'?

Yes. You or your contractor need to obtain a Special Drain Permit form from the DPIE. There is a permit fee.

17. My neighbors are washing their pool out and discharging water directly into my yard or into a nearby stream. Is this legal'?

No. Contact the Department of the Environment, Stormwater Management Division to report this activity.

18. My neighbor has installed a fence across the drainage swale and, as a result, the water flow has been hindered. Can the County cite my neighbor'?

The County may be able to cite your neighbor if the drainage course is being blocked. Contact the DPIE License & Inspection Group.

19. The storm drain curb inlet in front of my home is blocked. Whom should I contact to correct the situation'?

The Department of Public Works and Transportation, Storm Drainage Maintenance Division.

20. Our community pond is becoming an eyesore and a safety hazard. Who is responsible for maintenance of the facility'?

Most likely, your Homeowners Association is responsible for the aesthetic maintenance of the pond. You may contact the County's Department of Public Works and Transportation to find out if the County is responsible for maintenance. The County performs functional maintenance in that they mow the embankment and clear obstructions from the outlet structures on an annual basis. Aesthetic maintenance of the pond may be undertaken by citizens with written permission from the County.

.....

- 21. The stream behind my home floods onto my property. What programs are available to assist me in stabilizing my property from further erosion?**

The County has a stream stabilization program. This program is for significant erosion affecting several properties, and not isolated properties unless the erosion is significant. There are stabilization measures that can be taken by the homeowner. See page 13.

- 22. I am looking for a new home in Prince George's County. What should I look for to make sure drainage around the home is designed properly?**

Visit the property during or just after a rain event to make sure that the grading around the house is directed away from the foundation and water does not pond in the yard. See page 15 for more information.

- 23. My neighbor is dumping water onto the sidewalk and roadway, creating unsightly and hazardous conditions. Is there something the County can do to stop this?**

If the road is a County maintained road, contact the Prince George's County Department of Public Works and Transportation, Office of Engineering. If the road is a State maintained road, contact the State Highway Administration. If you live in a municipality, you should call your Town or City Hall.

- 24. My neighbors have installed pipe extensions on their downspouts. The water now flows with more intensity toward my garden causing damage to my property. What actions can I take to prevent this condition from continuing?**

Discuss the problem with your neighbor. Perhaps he can redirect the pipe extensions to avoid damage to your property.

- 25. Every time it rains, my yard becomes a raging river. I think I need a drainage system installed to convey the water properly. Can the County evaluate the problem and determine if a system is warranted?**

Yes. Contact the Department of the Environment. If the drainage area appears to be significant, a study may be performed to determine if the County should take further action.

- 26. The County installed a drainage system in my neighbor's backyard to correct a problem they were experiencing. Will the County solve my water problem too?**

Your situation requires evaluation to determine the extent of the problem. Involvement by the Department of the Environment depends upon the severity and scope of the problem.

- 27. I have been informed that my home is in a floodplain. What does this mean and are there any precautions that I should be taking to reduce my exposure to flood damage?**

It means that in the event of a major storm, your property could be flooded. Purchasing flood insurance is highly recommended. In addition, obtain detailed information on your flood elevation and see how your

home can be retrofitted or floodproofed. See "Moving to a New Home" on page 15 for more information.

- 28. My property is one of the lowest lots in our community, therefore, all water flow gravitates to my lot. What can I do to divert the water into an efficient drainage course?**

Perform minor grading or landscaping. Consult a professional landscaper and be sure to obtain all applicable permits.

- 29. Beavers have created a dam on the County property behind my home causing flooding. How can the beavers be removed?**

Call a licensed, private pest removal company, the Maryland-National Capital Park and Planning Commission, or the Department of Natural Resources. They can give suggestions on steps you can take.

- 30. I live near a wooded stream and I have noticed an increase in mosquitoes in the area. What can be done to control the presence of mosquitoes?**

Remove any impediments or blockages to the stream flow to prevent ponding water. Encourage birds, bats, and frogs to inhabit the area. See page 11 for other suggestions, or call the Maryland Department of Agriculture, Mosquito Control.

- 31. A sink hole has developed in my yard. I have repeatedly filled in the hole, but to my despair, it keeps reappearing. I am at my wit's end! Can the County help determine the cause?**

The Washington Suburban Sanitary Commission (WSSC) can determine if there are sewer or water lines in the vicinity of the sink hole. In the absence of a WSSC line, the County can determine if there is a public storm drain in the vicinity of the sink hole. If the sink hole is unrelated to WSSC or County lines, it is the property owner's responsibility to find out the cause and make corrections. If an abandoned well or septic system is suspected or discovered, contact the Health Department for information.

- 32. I recently purchased a home and noticed that the homeowner documents include something about a stormwater management easement. What is an easement and can I still use the area for my continued enjoyment?**

An easement is an area of land where permission to perform certain activities has been given by the grantor (usually the property owner) to the grantee (often a utility company or government agency). There are certain restrictions which may apply to an easement. For example, you may not be able to build permanent structures within the easement area, such as fences, sheds, etc. Check with the appropriate authority for details about a specific easement area.

- 33. My neighbors have dug a trench on their property and now all the water flows toward my property. How can I have the original drainage patterns re-established?**

Discuss the matter with your neighbors and ask them to correct the problem. You may want to consider a joint project that will benefit both properties. If they refuse to cooperate, the only alternative may be to seek legal advice.



APPENDIX C

Residential Drainage Maintenance Checklist

Many times, drainage problems affecting your home and/or property can be corrected through simple examination and maintenance. The following list provides items to look for to help control or mitigate sources of water problems. Most of these items are routine maintenance activities and can help reduce major maintenance problems in the future.

ROOF: *Leaks from the roof do not necessarily appear at the exact trouble spot location. Often, water that penetrates the roof is able to enter the home along joints or cracks in the walls.*

- Check for broken. Curling, missing shingles.
- Check flashing joints and caulk as needed.
- Check ceilings on upper floors and along roof line for water spots, indicating roof leaks.
- Check roof annually and after every major rain storm.

GUTTERS AND DOWNSPOUTS:

- Check for sags in gutters and tightness of gutter nails to fascia board.
- Check downspouts for blockage or obstruction. This can be accomplished by flushing the downspout with a yard hose.
- Check for signs of dripping beneath the gutter rail.
- During Winter months, check for standing water in the gutter rail. Standing water in the gutters can lead to ice dam conditions.
- Check during rain storm events for overflow conditions. Evidence of overflow may be present on the ground directly below the gutter rail, usually in a rilling pattern.
- Check gutters every Spring and Fall for obstructions and after every major rain storm event.

GUTTER SHOES AND SPLASHBLOCKS:

- Check the bottom of the downspout to ensure the gutter shoe is tightly in place and directed to a splashblock, and in turn, discharges the water away from the foundation.
- Check for signs of erosion or mud at downspout locations. Correct with vegetative cover or landscaping materials such as stones.
- Inspect every spring and fall.

WINDOWS AND DOORS: *Windows and doors are the most common entry point for water due to the number of joints and seams.*

- Inspect insulation around the doors and windows for water tightness as well as air tightness. Note of caution for windows: most window casings have small openings at the bottom to allow the interior side to "breathe". Due to the temperature difference between the outdoors and indoors, windows commonly produce condensation on the interior surfaces. The small openings provide a way for the condensate to exit to the outdoors.
- Also check siding adjacent to windows ("J" channel).

CHIMNEYS:

- Inspect mortar joints for openings and seal with suitable cement compounds.
- Check flashing around chimney and seal all openings with caulking. If not already present, install a chimney cap to keep rain and pests from entering the interior of the chimney.

WINDOW WELLS:

- Install window well covers over all window wells to help keep moisture away from the foundation wall and window area.
- Inspect grading adjacent to window well. All any voids, and compact with the back of a shovel blade.

WINDOW AIR CONDITIONING UNITS:

- Inspect seal around the unit and make sure condensation produced by the unit is dripping away from the side of the home. Drip plates and pans can be used for this purpose.
- Check drip pans and unit regularly for maintenance.

CRAWL SPACES: *Typically, crawl spaces are composed of the existing earth bottom and can collect dampness due to condensation. Sometimes the dampness can be controlled by installing insulation or vapor barrier materials. Crawl spaces can collect water beneath the home if the grade is not directed away from the crawl space area. Additionally, groundwater seepage can collect in the crawl space. While this condition in itself is not necessarily damaging to the home, water and darkness are conducive to insect infestations.*

- Check crawl spaces periodically for standing water and insect infestations.

EXPOSED OR DAMP WOOD: *Exposed or damp wood is susceptible to damage or deterioration over time. The dampening of wood can cause rotting out and decay.*

- Check exposed wood for signs of insects or decay. Termites and other insects feed on decaying wood matter which can lead to serious structural damage.
- Paint all exposed wood and replace any damp or damaged wood.
- Caulk any joint openings in wood surfaces.

WALKOUT AREAWAY DRAIN: *Aside from doors and windows, area drains that become overwhelmed during a heavy rainstorm can backup and flood into the home through the door seams.*

- Keep areaway drain clear of obstruction and check drain line by snaking out the line on at least an annual basis.
- Make sure that the area drain is protected with a screen or strain to prevent the drain pipe from becoming blocked.

SUMP PUMPS:

- Check sump pump for operation on an annual basis. Pour a bucket of water into the sump pit. taking care not to pour water on any electrical connections. Fill the sump pit until the sump pump turns on by triggering the float.
 - Inspect discharge points outside and ensure that the discharge water does not cause drainage problems for your neighbor.
- For peace of mind. install a battery backup system or install a stand-ready redundant pump which is available from your local hardware store.
-

DRIVEWAYS:

- For driveways next to homes, check for settlement and slope away from the home.
- Make sure water does not have an opportunity to collect in seams or cracks in the driveway.
- Avoid draining water from downspouts or sump pumps onto the driveway.
- Avoid corrosive de-icing salts and chemical applications on concrete driveways.

PATIOS AND WALKWAYS:

- Check for settlement cracks.
- Do not use corrosive de-icing salts or chemicals on concrete.
- Look for Assures next to the house where concrete abuts the side of the home. Seal with weather resistant silicone caulking.
- Check slopes of concrete patios and walkways to ensure that positive flow is away from the home's foundation.

YARDS AND LAWNS:

- Control erosion problem areas by installing landscaping ground cover such as periwinkle.
- Hide water problem areas with landscape stone or work with the water and create a water feature or rain garden. See manual for more information.
- Planting of grass or most vegetation is done best in the late fall season.

GRADING AND LANDSCAPING: *Design landscapes with drainage in mind. Be sure not to block drainage courses or re-direct water onto adjacent properties. Grading activities generally require permits and necessitate erosion control devices during the grading operation. Existing grading around the home should be draining away from the home's foundation area.*

- Check the grading adjacent to the home for cracks, Assures, and/or sumps. Over time, some settlement of grading is normal and should be inspected for corrective action as needed on an annual basis.
- Check grading around the home on an annual basis. Susceptible areas for grading problems near the home are around window wells, walkout stairways, corners of home.

APPENDIX D

Vegetative Ground Cover for Protection Against Erosion

GRASSES

	For Maintained Lawn Areas	For Non-Maintained Lawn Areas
SUNNY AREAS	Kentucky Bluegrass Bermudagrass Mixtures	Kentucky 31 Tall Fescue Kentucky Bluegrass Mixtures
SHADY AREAS	Kentucky Bluegrass Creeping Red Fescue Bermudagrass Mixtures	Same as above

OTHER GROUND COVERS

SUNNY AREAS	Spreading Junipers Creeping Thyme	Crownvetch Birdsfoot Trefoil
SHADY AREAS	Pachysandra Periwinkle	Same as above

SHRUBS & TREES (Generally suited for all areas)

SHRUBS	Junipers Memorial Rose Rem Red Amur Honeysuckle Five Leaf Akebia
TREES	Willow Bristly Locust Birches (Native) European Black Alder

Contact the Soil Conservation District for expert recommendations.

VEGETATIVE PLANTS FOR WET AREAS (Generally suited for wet areas)

Daylilies	
Virginia Bluebell	
Astilbe	
Assorted ferns	”

Visit the Prince George's County Department of the Environment's website at: <http://www.princegeorgescountymd.gov/Government/AgencyIndex/DER/ESG/manuals.asp> to view a copy of the publication, *"A Rain Garden Reference Guide-How Does Your Garden Grow?"* This publication contains creative methods to enhance and environmentally restore wet areas.

APPENDIX E

Guide to Government Agencies and Offices

Government agencies and offices in Prince George's County which may be of assistance to work described in this publication are listed below:

Soil Testing & Planting Recommendations

Prince George's County Horticultural Agent
6707 Groveton Drive. Clinton. MD 20735
301-868-8781

Prince George's County Cooperative Extension Service
University of Maryland
Home and Garden Information Center
6707 Groveton Drive. Clinton. MD 20735
301-868-9366 1-800-342-2507

Information and Homesite Erosion, Sedimentation and Soils

U.S. Department of Agriculture-Natural Resource
Conservation Service
Southern Maryland Resource Conservation and Development
303 Post Office Road. Suite B4A
Waldorf. MD 20602

Prince George's County Soil Conservation District
5301 Marlboro Race Track Road. Suite 100
Upper Marlboro. MD 20772
301-574-5162

Prince George's County Permits (*Permitting authority varies with local jurisdictions.*) The agencies listed below should be contacted to identify code enforcement and to report sedimentation and erosion due to construction .

Prince George's County Department of Permitting, Inspections & Enforcement
Office of Engineering
9400 Peppercorn Place, 1st Floor
Largo. MD 20774
301-833-5987

Special Drain Permits 301-883-5710
Building Permits 301-883-3820

Maryland Department of the Environment
Water Management Administration
Engineering and Construction Permit Program
1800 Washington Boulevard
Baltimore. MD 21230
1-40-537-3000 1-800-633-6101

Environmental Permits Service Center
1 -410-537-3772

Sediment and Erosion Information and Citizens Complaints
1-410-537-3510

To Report Clogged Public Storm Drains

Prince George's County Department of Public Works
and Transportation
Storm Drainage Maintenance Division
8400 D'Arcy Road
Forestville, MD 20774
301-499-8520
After 4:00 pm and Weekends 301-499-8600

Flood Insurance Information

National Flood Insurance Program
Box 34294
Lanham, MD 20034
1-800-427-Li661 1-888-356-6329

OTHER AGENCIES

Maryland Department of Natural Resources
Tawes State Office Building
580 Taylor Avenue
Annapolis, MD 21401
1-410-260-8100

Prince George's County Health Department
Division of Environmental Health
9201 Basil Court - Suite 318
Largo, MD 20774
301-883-7681

Mosquito Control 1-410-841-5870

Maryland-National Capital Park and Planning Commission
Natural Resources Division
County Administration Building
1474 1 Governor Oden Bowie Drive Upper
Marlboro, MD 20772
301-952-3650

QUICK REFERENCE NUMBERS

Chesapeake Bay Critical Area Commission	410-260-3478
Comprehensive Community Clean-up	301-883-7161
Comprehensive Watershed Management Plans	301-883-5810
Flood Warning System	301-883-5810
Flooding and Erosion Problems	3-1-1
Floodplain Inquiry Service	301-883-5777
Floodplain Review Process	301-883-5777
Maryland Department of the Environment (MDE)	1-800-633-6101
National Flood Insurance Program	1-800-Li27-Li661
Prince George's County	301-883-3311
State Floodplain Coordinator	410-537-3775
Federal Region III Coordinator	215-931-5500
Maryland Department of the Environment (MDE)	410-537-3000
Natural Resources Conservation Service	301-932-Li638
Prince George's County Property Standards	301-883-6022
Housing Code Enforcement	301-883-6100
Zoning Enforcement	301-883-6100
Property Maintenance/Clean Lot	301-883-6100
(Issuance Signs)	301-883-6100
Abandoned Vehicles	3-1-1
Commission for Animal Control	301-883-6009
Prince George's County Business License Office	301-883-38Li0
State Business License Office	301-952-3331
Prince George's County Cooperative Extension Service	301-868-9366
Prince George's County Department of Permitting, Inspections and Enforcement	
Permits and Review Group	301-636-2000
License and Inspection Group	301-883-3840
Prince George's County Health Department	
Division of Environmental Health	301-883-7605
Prince George's County Soil Conservation District	301-57Li-5162
Prince George's County Department of Public Works and Transportation	301-883-5600
Road Maintenance Issues	
State Roads	301-513-7300
County Roads	301-499-8520
Wetland Permits	
MDE, Nontidal Wetlands & Waterway Construction	410-537-3768
US Army Corps of Engineers	410-962-3670
Water & Sewer Line Problems	301-206-8002
Washington Suburban Sanitary Commission	301-206-8000



A Public Service Publication of the Prince George's County Government

Additional copies of this publication can be obtained
from the Department of the Environment

